

Safety Relay H-462

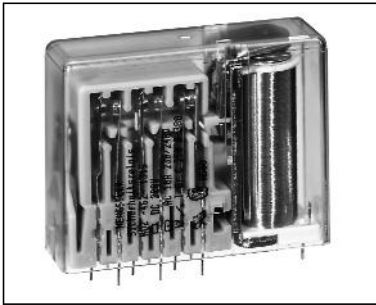

General

- 4 or 6 contacts
- Forced guided contact set
- According to IEC/EN 61810-3, type A
- Ambient temperature -25 ... +80 °C
- Soldering heat resistance 260 °C/5s
- RoHS compliance
- Signalling relay according to DIN EN 50578 (UIC 736E)

Connections

- Soldering pins for PCB, pre-soldered

Drive

- DC or AC
- Current controlled or bistable upon request

Approvals

- cULus • TÜV

Standards

- IEC/EN 61810-1 • IEC/EN 61810-3
- DIN EN 50578 (UIC 736E) • UL 508

Technical Data mechanical

Dimensions L x W x H (in mm)

Size 1: 57,8 x 20,5 x 48,6

Size 2: 67,4 x 20,5 x 48,6

Shock resistance NO-contact/NC-contact
Vibration resistance NO-contact/NC-contact

10/10 g, 16 ms Half sinus
10/10 g, 10 – 55 Hz

Operating time NC-contact, contact opens
Operating time NO-contact, contact closes
Releasing time NO-contact, contact opens
Releasing time NC-contact, contact closes

typical 17 ms
typical 23 ms
typical 5 ms
typical 7 ms

Mechanical service life (without load)
Weight

>10⁷ cycles
Size 1: 90 g
Size 2: 115 g

Technical Data electrical

Max. switching capacity

AC 2.000 VA, DC *W

Max. switching voltage

AC 230/240 V, DC *V

Max. switching current NO-contact

10 A

Constant current I_{th2}

10 A

Constant current I_{th2} at the same time over 2 contacts

10 A

Constant current I_{th2} at the same time over 3 contacts

10 A

Constant current I_{th2} at the same time over 4 contacts

10 A

Switching capacity NO-contact AC-15 230/240 V
DC-13 24 V

I_e = 4 A
I_e = 2 A

Electrical service life (with nominal load)

>10⁵ cycles

Short-circuit capacity 1.000 A/AC 230 V

10 A gL/gG-fuse

* see DC-switching capacity

Insulation

Over voltage category (Ü) III

B-I = Basic insulation

Degree of pollution (V) 2

V-I = Reinforced (double) insulation

Insulating material group II

Insulation between	Nominal voltage network system		Air-/creeping distance	Test voltage 50Hz/60 s
	AC 120/240 V	AC 230/400 V		
Contact – Contact	V-I	B-I	> 3 mm	AC 2.500 V
Contactset – Drive	V-I	B-I	> 3 mm	AC 2.500 V

Dimensions

H-462 Size 1 (4 contacts)

H-462 Size 2 (6 contacts)

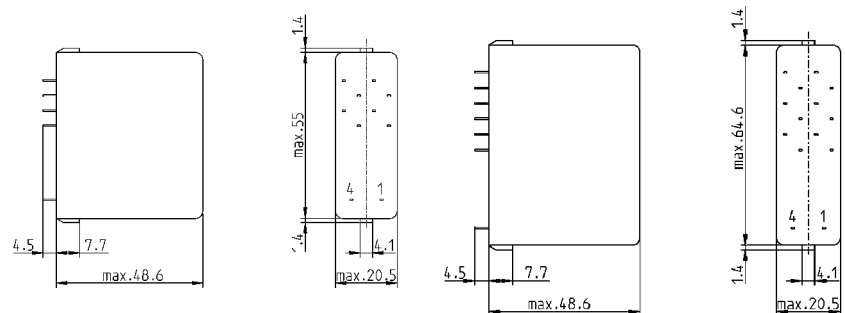

Safety Relay H-462

Type key

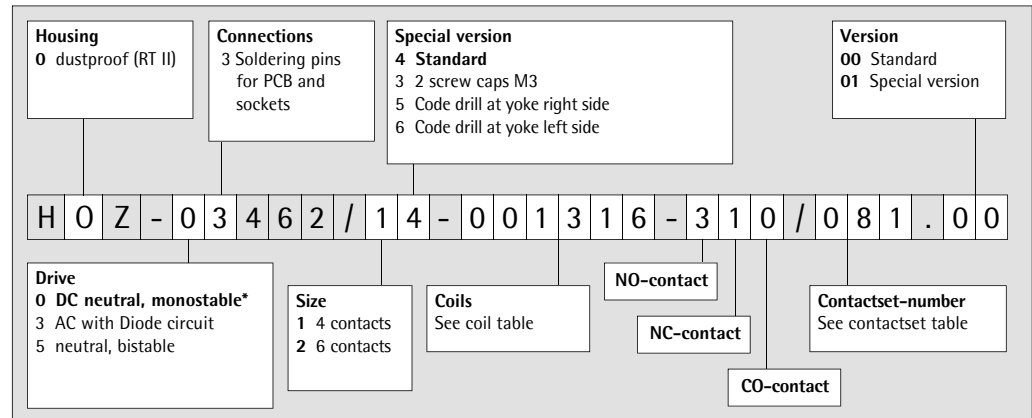

* Preferred version

Contactset table

Contact material AgCdO
since 2018 no longer available!

Number of contacts NO/NC/CO-contacts	AgCdO +0,2 µm Au	AgCdO +5 µm Au	AgCdO +10 µm Au	AgSnO ₂ +0,2 µm Au	AgSnO ₂ +5 µm A	Contact material
220	080	082	061	088	092	Contactset number
310	079	081	059	087	091	
330	077	084	057	085	090	
420	078	083	055	086	089	

All values at ambient temperature $T_u = 20\text{ °C}$

DC-Coil table

Number of contacts
310
220

Coil-No.	Resistance R/Ω	Resistance- tolerance±	U ₁ /V	U ₂ /V	U ₃ /V	U _{rück} /V	Printing U _{nom} /V
1228	33	5%	3,4	11,6	11	0,8	6
1323	110	6%	6,2	21,2	19	1,4	12
1316	480	8%	13,9	43,9	42	3,0	24
1312	1.700	7%	27,3	82,9	83	5,9	48
1311	2.700	7%	34,4	104,4	104	7,4	60
1306	10.000	9%	69,8	199,7	205	14,7	110
1303	40.000	12%	139,8	395,0	394	28,2	220

All values at ambient temperature $T_u = 20\text{ °C}$

Number of contacts
420

Coil-No.	Resistance R/Ω	Resistance- tolerance ±	U ₁ /V	U ₂ /V	U ₃ /V	U _{rück} /V	Printing U _{nom} /V
1228	33	5%	3,7	11,6	11	0,8	6
1323	110	6%	6,9	21,2	19	1,4	12
1316	480	8%	15,5	43,9	42	3,0	24
1312	1.700	7%	30,3	82,9	83	5,9	48
1311	2.700	7%	38,2	104,4	104	7,4	60
1306	10.000	9%	77,8	199,7	205	14,7	110
1303	40.000	12%	155,7	395,0	394	28,2	220

U₁: Minimum operating voltage with consideration of coil self heating
 U₂: Thermal restricted maximum coil voltage
 U₃: Maximum admissible coil voltage to realize a contact gap of > 0.5 mm also at a contact fault
 U_{rück}: Releasing voltage

Further coils are possible and available

Safety Relay H-462

All values at ambient temperature $T_u = 20\text{ °C}$

DC-Coil table
Number of contacts
330

Coil-No.	Resistance R/ Ω	Resistance- tolerance \pm	U_1/V	U_2/V	U_3/V	$U_{rück}/V$	Printing U_{nom}/V
1228	33	5%	4,1	11,6	11	0,8	6
1323	110	6%	7,6	21,2	19	1,4	12
1316	480	8%	17,1	43,9	42	3,0	24
1312	1.700	7%	33,5	82,9	83	5,9	48
1268	2.650	7%	39,5	103,5	98	7,0	60
1306	10.000	9%	86,0	199,7	205	14,7	110
1303	40.000	12%	172,2	395,0	394	28,2	220

U_1 : Minimum operating voltage with consideration of coil self heating
 U_2 : Thermal restricted maximum coil voltage
 U_3 : Maximum admissible coil voltage to realize a contact gap of $> 0.5\text{ mm}$ also at a contact fault
 $U_{rück}$: Releasing voltage

Further coils are possible and available

All values at ambient temperature $T_u = 20\text{ °C}$

AC-Coil table
Number of contacts
220
310
330
420

Coil-No.	Resistance R/ Ω	Resistance- tolerance \pm	U_{min}/V	U_{max}/V	Printing U_{nom}/V
1128	30	10%	9,6	13,2	12
1323	110	10%	19,2	26,4	24
1316	480	10%	38,4	52,8	48
1514	750	10%	48,0	66,0	60
1311	2.700	15%	88,0	121,0	110/115
1306	10.000	15%	176,0	242,0	220/230

Further coils are possible and available

Running types

Article-No.	Type key	Printing U_{nom}	U_1/V	U_2/V	U_3/V	$U_{rück}/V$
462-1529	HOZ-03462/14-001316-220/088.00	DC 24 V	13,9	43,9	42	3,0
462-1475	HOZ-03462/14-001316-310/087.00	DC 24 V	13,9	43,9	42	3,0
462-1542	HOZ-03462/24-001316-330/085.00	DC 24 V	17,1	43,9	42	3,0
462-1577	HOZ-03462/14-001323-310/087.00	DC 12 V	6,2	21,2	19	1,4
462-1541	HOZ-03462/24-001316-420/086.00	DC 24 V	15,5	43,9	42	3,0
462-1532	HOZ-03462/24-001316-330/090.00	DC 24 V	17,1	43,9	42	3,0
462-1471	HOZ-03462/14-001316-310/091.00	DC 24 V	13,9	43,9	42	3,0
462-1550	HOZ-03462/14-001323-220/092.00	DC 12 V	6,2	21,2	19	1,4
462-1551	HOZ-03462/14-001312-220/092.00	DC 48 V	27,3	82,9	83	5,9
462-1499	HOZ-03462/24-001323-420/089.00	DC 12 V	6,9	21,2	19	1,4
462-1500	HOZ-03462/24-001316-420/089.00	DC 24 V	15,5	43,9	42	3,0
462-1552	HOZ-03462/24-001312-330/090.00	DC 48 V	33,5	82,9	83	5,9
462-1555	HOZ-03462/14-001323-310/091.00	DC 12 V	6,2	21,2	19	1,4

Safety Relay H-462

Connection grid
View on soldering side

Size 1

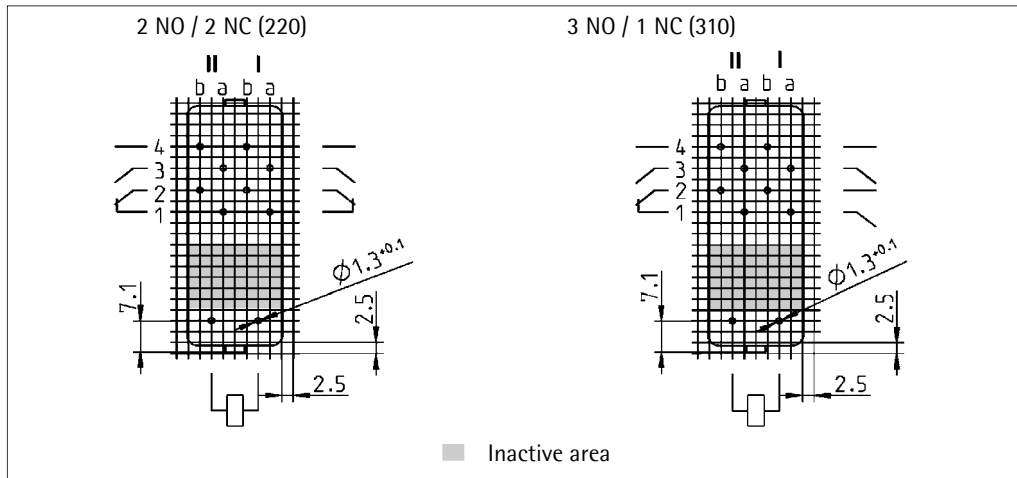

Size 2

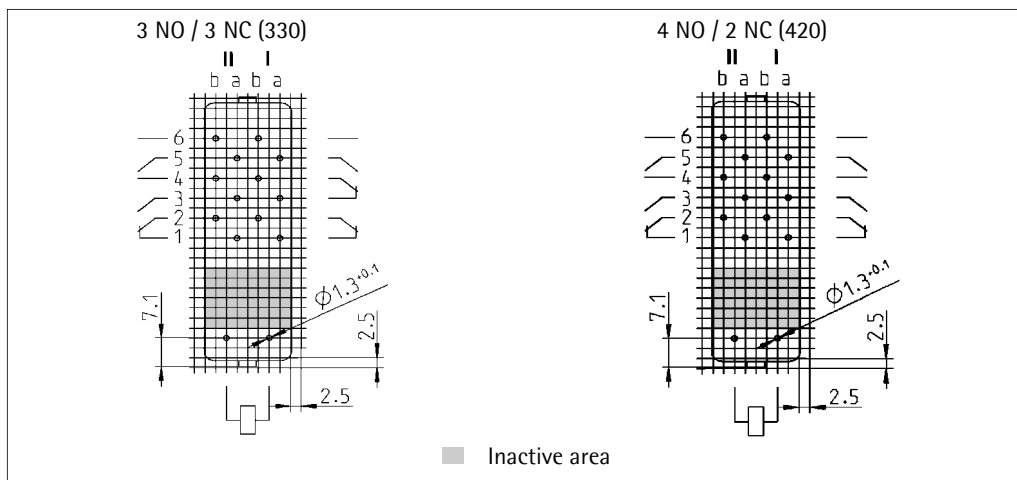

Diagram

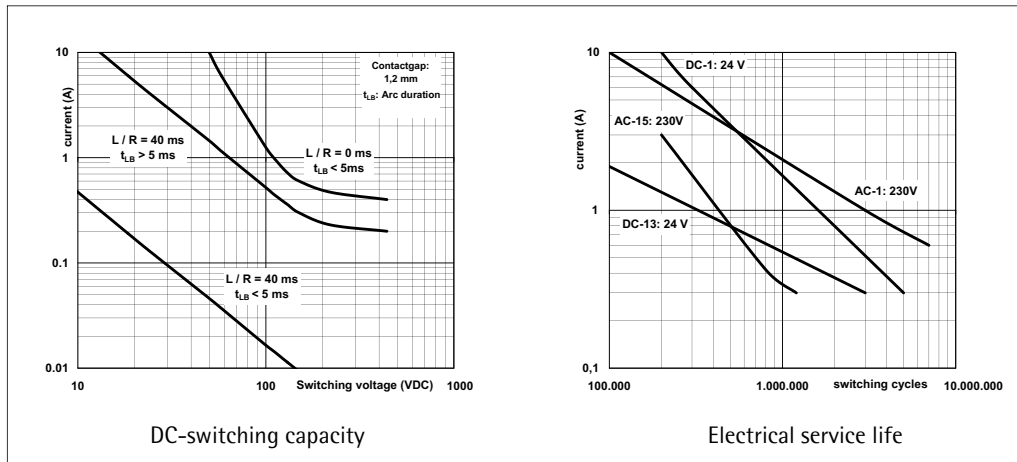

Safety Relay H-462

Accessories
H-462/2
(6 contacts)

